



External Gear Pump

外嚙合齒輪泵



油壓記號

SYMBOL

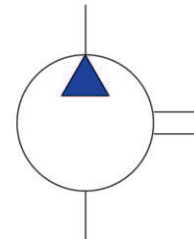

型式號碼/MODEL CODE

EGA - 4.3 - R

回轉方向 (由軸側方向觀之)

Direction of Rotation (View from shaft end)

R: 順時針方向

R: Clockwise

L: 逆時針方向

L: Counterclockwise

排量: c.c./rev

Displacement: c.c./rev

外嚙合齒輪泵系列

External Gear Pump Series

產品特性:

1. 高壓力、高效率。
2. 特殊齒型設計，低噪音，符合低噪音工作環境要求。
3. 體積小，節省機械空間。
4. 本體為鋁擠型合金，前後蓋為鋁合金壓鑄，質輕、堅韌、耐高壓。
5. 標準SAE "A" 四孔法蘭。

FEATURE:

1. High pressure and high efficiency applicable to all kinds of machines.
2. Special gear design, low noise, agreeable to low-noise requirement.
3. Compact body and space saving.
4. Aluminum alloy, gravity casting body. Light weight and Sturdiness.
5. Standard SAE "A" four port flange.



External Gear Pump 外啮合齒輪泵

技術資料/TECHNICAL DATA

型式 MODEL	泵排量 THROREITICAL DISPLACEMENT (c.c/rev.)	最高壓力 MAX. PRESSURE (kgf/cm ²)	容許回轉速 SHAFT SPEED RANGE (rpm)		尺寸 DIMENSION (MM)		重量 WEIGHT (kg)	出入口尺寸 IN/OUTLET DIMENSION(MM)	
			最高 MAX.	最低 MIN.	A	B		輸入 INLET	輸出 OUTLET
EGA-1.2	1.2	210	6000	600	75.5	37.8	1.0	10	10
EGA-1.7	1.7	210	6000	600	77	38.5	1.0	10	10
EGA-2.2	2.2	210	6000	600	79	39.5	1.0	10	10
EGA-2.6	2.6	210	6000	600	81	40.5	1.1	10	10
EGA-3.2	3.2	210	6000	600	83	41.5	1.1	12	12
EGA-3.8	3.8	210	6000	600	85	42.5	1.2	12	12
EGA-4.3	4.3	210	4000	600	87	43.5	1.2	12	12
EGA-6.2	6.2	210	4000	600	94	47	1.3	12	12
EGA-7.8	7.8	180	4000	600	100	50	1.4	12	12

尺寸圖/DIMENSION

單位 UNIT:mm

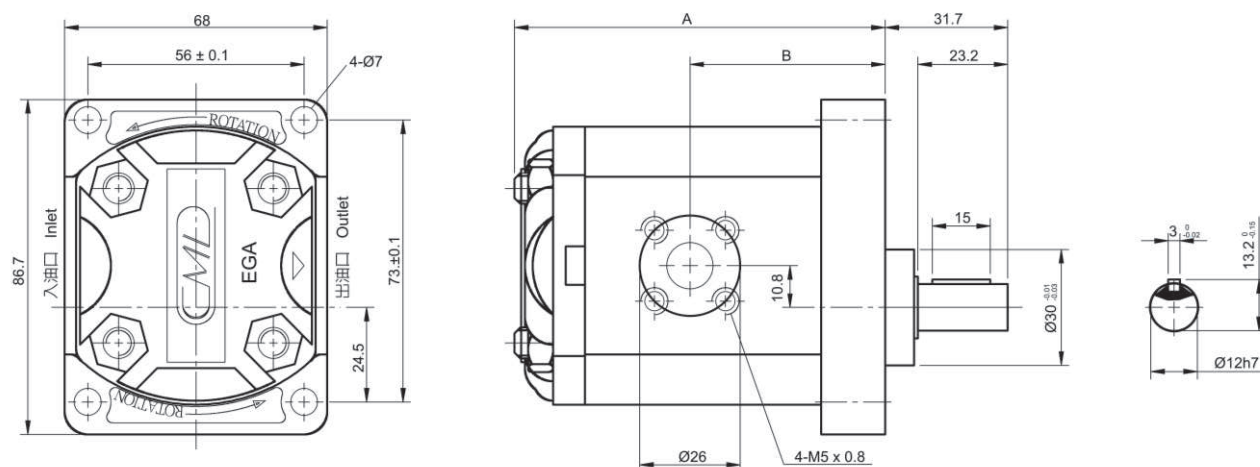

性能曲線圖/PERFORMANCE CURVES

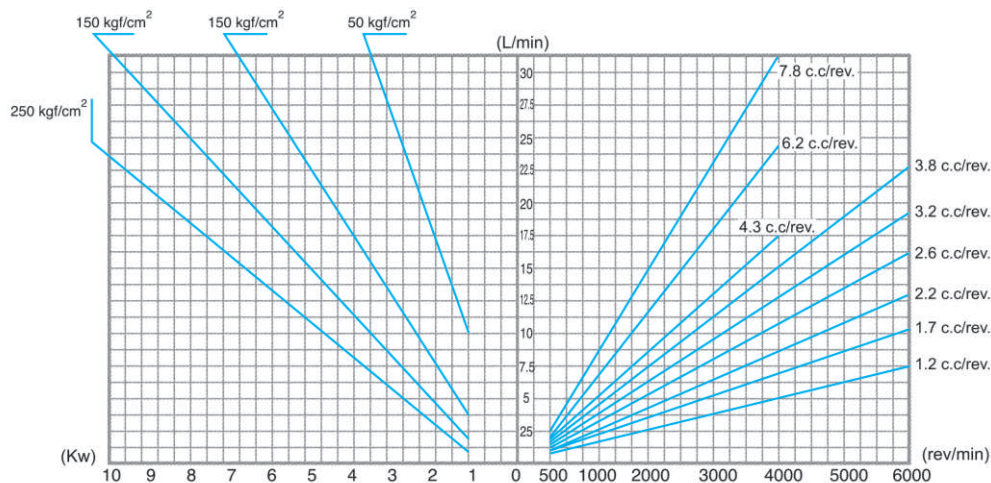



變量葉片泵

Variable Displacement Vane Pump



內齒合齒輪泵

Internal Gear Pump



外齒合齒輪泵

External Gear Pump



電磁方向控制閥

Solenoid Operated Directional Valve

操作說明

1. 安裝時須注意泵與馬達的同心度，泵的軸心不得承受任何的徑向或軸向壓力。
2. 液壓油
請使用添加抗氧化劑之石油基液壓油，以避免氧化、腐蝕及氣泡之產生。亦可使用機油，建議使用黏度 礦物油:3÷5E50 °C或是機油:SAE10、20、30等，視環境而定。
操作溫度範圍:15-70°C。
黏度:1.45 °E，啟動最大黏度:200 °E。
3. 過濾
在注油時應確保整個迴路清潔，並且須注意選用適當的濾油器，最好加裝油路阻塞感應器，並請依照濾油網規定按時更換。
建議選用:吸入口:90mesh，回油口:25mesh。
4. 管路安裝需知
 - 禁止折彎迴路及阻塞迴路。
 - 最大吸入壓力250mm/HG。
 - 吸入口最大流速:0.5÷1.5 M/sec。
 - 排出口最大流速:3÷8 M/sec。
 - 回油最大流速:2÷3 M/sec。

驅動系統

1. 驅動軸上不能承受任何徑向及軸向之壓力。
2. 馬達及泵的同心度必須仔細調整。
3. 請使用連軸器以補償軸心之偏心量。
4. 安裝連軸器時必須避免產生軸向壓力，嚴禁使用敲擊或強壓方式安裝。

通則

所有泵在出廠前已做過性能及功能測試，任何企圖對泵所做的修改，本公司不予任何保證。

所有泵維修僅限於本廠及經過授權之經銷商，任何非經授權之維修行為，本公司不予保證。

Operating Instruction

1. Pump must be installed with driving shaft coaxial to power take off. The drive system must not impose axial or radial load to pump shaft.
2. Hydraulic fluid
Use a mineral based hydraulic oil with additive to resist oxidation, Corrosion and foaming or an engine oil.
Recommended viscosity
Mineral oil 3 ÷ 5 E 50 °C --- Engine oil SAE 10, 20, 30 depending on environment temperature .
Operating Temperature range: 15 - 70 °C
viscosity: 1.45 °E
Maximum viscosity during starting: 200 °E
3. Filtration
Before filling the system, ensure that circuit is perfectly clean. Filter must be adequate in capacity and preferably with blockage indicators. Filter must be changed according to operating instructions.
Recommended filtering: Suction side 90 mesh, Return side 25 medium porosity.
4. Piping Instruction
Avoid sharp bends and restrictions on the circuit.
Maximum inlet depression: 250mm/Hg
Maximum oil speed suction side : 0.5 ÷ 1.5 M/sec
Maximum oil speed outlet side : 3 ÷ 8 M/sec
Maximum oil speed return side : 2 ÷ 3 M/sec

Drive system

1. No radial or axial forces may be permitted to act on the pump drive shaft.
2. The alignment of motor and pump must be adjusted precisely.
3. Always use a coupling which will permit compensation for any shaft displacement.
4. When mounting the coupling, avoid applying axial force, i.e. never attempt to press or knock into place using a hammer or similar instrument.

Notification

- Every pumps supplied by Camel have been passed by performance and function testing. Any attempts to modify the pump is not allowed and will not keep the warranty. Maintenance must be performed by the manufacturer or by authorized dealers. No warranty can be accepted for unauthorized repairs.
- Repairs may only be performed by the manufacturer or by authorized dealers and branches. No warranty can be accepted for unauthorized repairs.



全懋精機股份有限公司
CAMEL PRECISION CO., LTD

公司：台中市西屯區玉門路64號

OFFICE: No. 64, Yu-Men Road, 407, Taichung, Taiwan

工廠：彰化縣田中鎮中州路二段455號

FACTORY: No. 455, Sec. 2, Chung-Zow Road, Tenchung, Chang-Hwa, Taiwan

TEL: +886-4-24615707 FAX: +886-24618842

E-mail: sales@camel555.com.tw <http://www.camel555.com.tw>